

Reinhold Environmental Ltd.



2010 NO_x-Combustion Round Table & Expo Presentation

February 8 & 9, 2010

Chattanooga, TN

All presentations posted on this website are copyrighted by Reinhold Environmental, Ltd (RE). Any unauthorized downloading, attempts to modify or to incorporate into other presentations, link to other websites, or obtain copies for any other uses than the training of attendees to RE's Conferences is expressly prohibited, unless approved in writing by RE or the original presenter. RE does not assume any liability for the accuracy or contents of any materials contained in this library which were presented and/or created by persons who were not employees of RE.



Evonik Energy Services



EVONIK
INDUSTRIES

AIG Tuning Tips for better tuning results

by Marilyn Martin



EVONIK
INDUSTRIES

Evonik Energy Services



We always go the full circle and provide our services as “Operator Engineers”

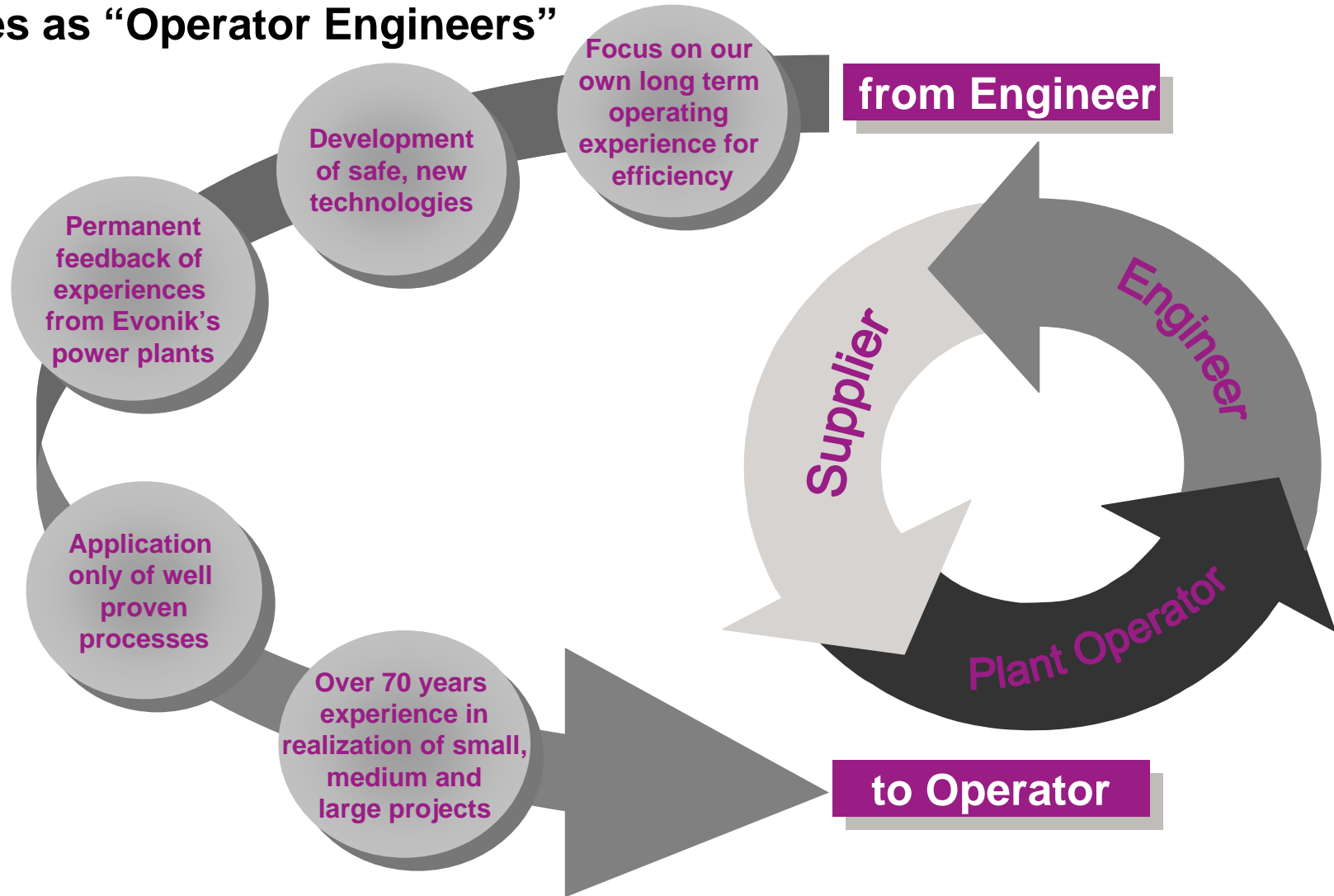

Evonik Energy Services



AIG Tuning – Part of Proper SCR Management

- **Evonik's 20 years of experience operating 24 SCRs has proved the necessity of annual AIG system tuning:**
 - **Maximizes NO_x removal efficiency**
 - **Optimizes SCR operation**
 - **Optimizes AIG system operation**
 - **Reduces NH₃ consumption**
 - **Minimizes ammonia (NH₃) slip**
 - **Reduces O & M costs**
 - **Compare catalyst sampling results with expected results / deactivation**



**ECOS AIG
Tuning Truck**

Evonik Energy Services



Keys To Successful AIG Tuning – Do's and Don'ts

- **Pre-tuning Preparations**
 - **On-site inspection of the AIG system**
 - **Review system information (drawings, diagrams, etc.)**
 - **SCR layout**
 - **Ammonia injection grid design**
 - **Sampling grid design**
 - **Confirm there is a fixed installed sampling grid after the last catalyst layer**
 - **Review AIG equipment availability**
 - **Are there differential pressure transmitters or gauges on the tuning valves (indicator of changes being made)?**
 - **Are the tuning valves frozen closed or locked?**
 - **Are the sampling lines unplugged?**

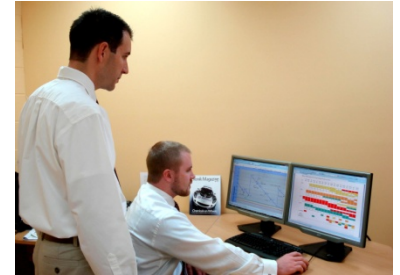

Review System
Documentation

Evonik Energy Services



Keys To Successful AIG Tuning – Do's and Don'ts

- **Pre-tuning Preparation**
 - **Confirm all test ports are free of air in-leakage and correctly labeled to correspond with points inside the reactor**
 - **Evaluate test site access and need for hoist/and or crane to move equipment to test location**
 - **Inquire on availability of plant personnel to assist in moving testing equipment to test locating**
 - **Determine what safety training / equipment / precautions plant requires and include additional time in schedule**



Multi-point NO_x/O₂
Analyzer Set-up

Evonik Energy Services



Keys To Successful AIG Tuning – Do's and Don'ts

- **Good Communication Between Plant And Testing Crew**
 - **Communicate directly with plant manager, SCR / AIG system operator and control room operator**
 - **Confirm tuning schedule with plant personnel**
 - **Moving equipment to test location (1 day)**
 - **Calibrating instrumentation (1 day)**
 - **Tuning (2 days if unit is stable and reactor is close to optimum)**
 - **Removing equipment from test location (1 day)**
 - **Can reduce time if two units are side by side and tuned at the same time; set-up equipment between the two units and run longer lines**



Ammonia Header
And Take-Off Trunks

Evonik Energy Services



Keys To Successful AIG Tuning – Do's and Don'ts

- **Good Communication Between Plant And Testing Crew**
 - **Outline what is required of the plant during the tuning, namely:**
 - **Unit must be operated at full load on a continuous basis during the entire scheduled testing period**
 - **Assure during tuning that there is**
 - **Maximum flue gas volume and NOx flow rate through the SCR**
 - **Design NOx removal efficiency (e.g. 90%)**
 - **Note: Tuning at lesser demanding conditions (i.e. partial load, lower NOx removal efficiency etc.) will result in inferior AIG tuning results.**



AIG Tuning Grid
Sampling Ports

Evonik Energy Services



Keys To Successful AIG Tuning – Do's and Don'ts

- **Tuning: Procedure**
 - **Calibrate equipment upon set-up**
 - **Run test quality gas through system for reference point**
 - **Perform actual AIG tuning**
 - **Coordinate computer results after each run**
 - **At completion of test, mark final valve positions**
 - **Lock valves in position so they cannot be accidentally moved**



AIG Tuning
Valves

Evonik Energy Services



Keys To Successful AIG Tuning – Do's and Don'ts

- **Tuning: Compare Before and After Conditions**
 - **Chart for the “as found” condition that gives each point value along with the average for the entire grid with a minimum value indication given for that data chart and a maximum value given for the data chart.**
 - **Provide information for the initial starting point of each AIG reactor tuned enabling the operator to know just where the starting point is for each point on the grid and how off from the average the reactor is at the various points.**
 - **Chart that gives the same data for the “as left” condition so that when unit is tuned next year, comparison of the data can be made to determine how much the unit has drifted from the last tuning.**



AIG Tuning
Valves

Evonik Energy Services



AIG Tuning with Evonik's ECOS (Emissions Control and Optimization System) allows for:

- Using up to 7 NO/O₂ analyzers in parallel
- Generating a fully O₂-corrected 3-dimensional NO profile after the last catalyst layer for up to 100 sampling points in about 30 minutes.
- Tuning quality within about +/- 10 ppm NO after the last catalyst layer

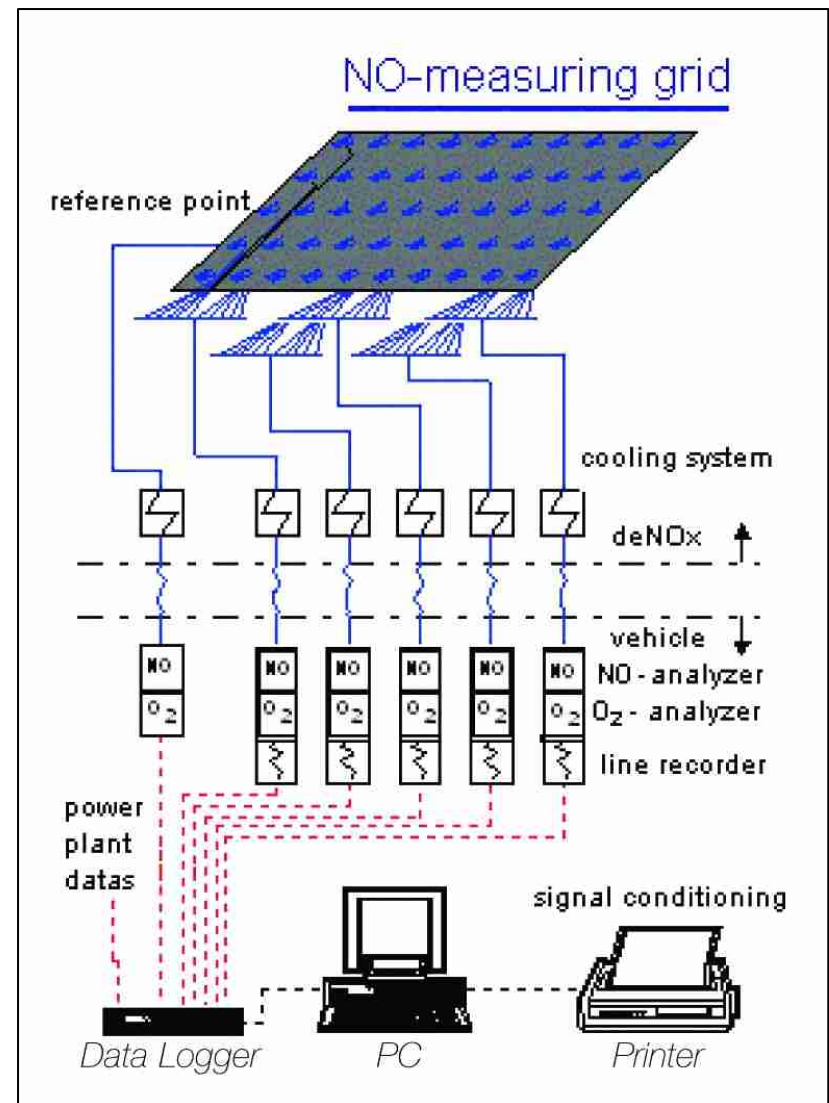

AIG Tuning: SCR Performance Monitoring – US Utility Before AIG Tuning

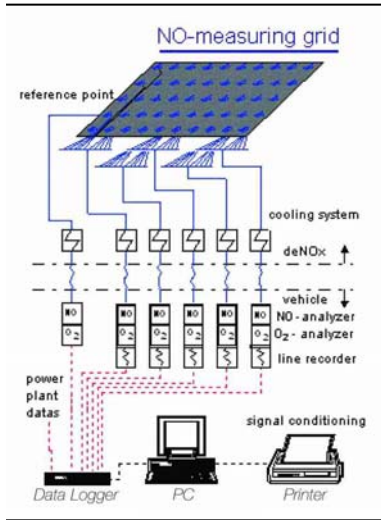

Evonik's ECOS

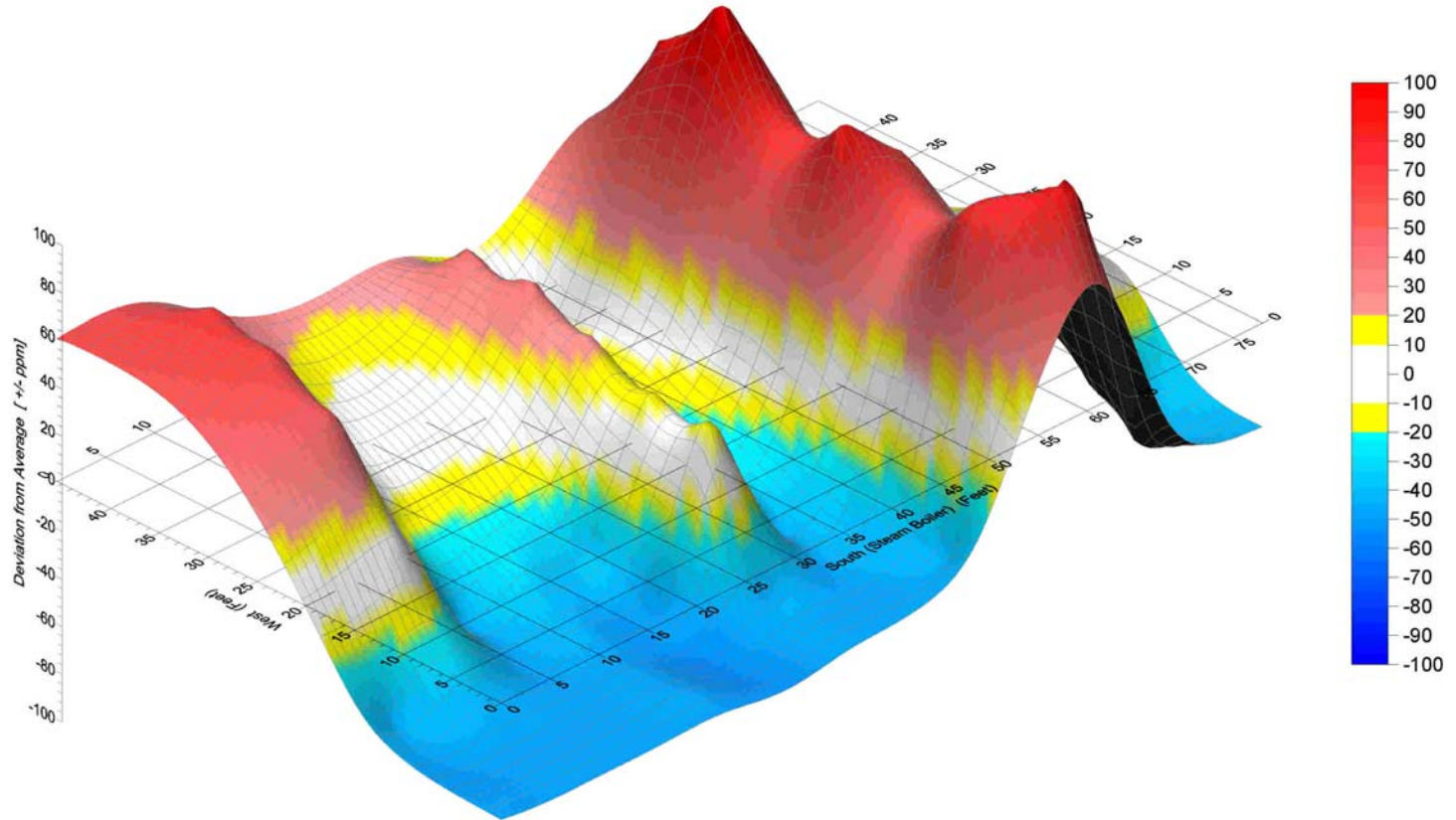

AIG Tuning: SCR Performance Monitoring – US Utility After AIG Tuning

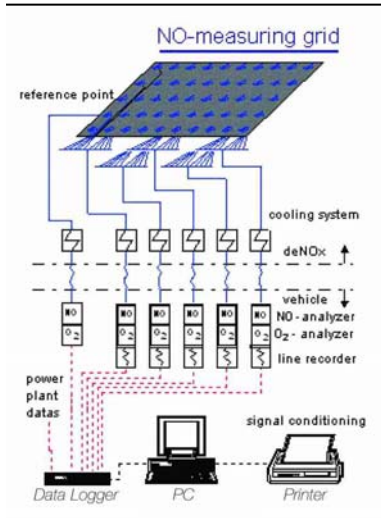

Evonik's ECOS

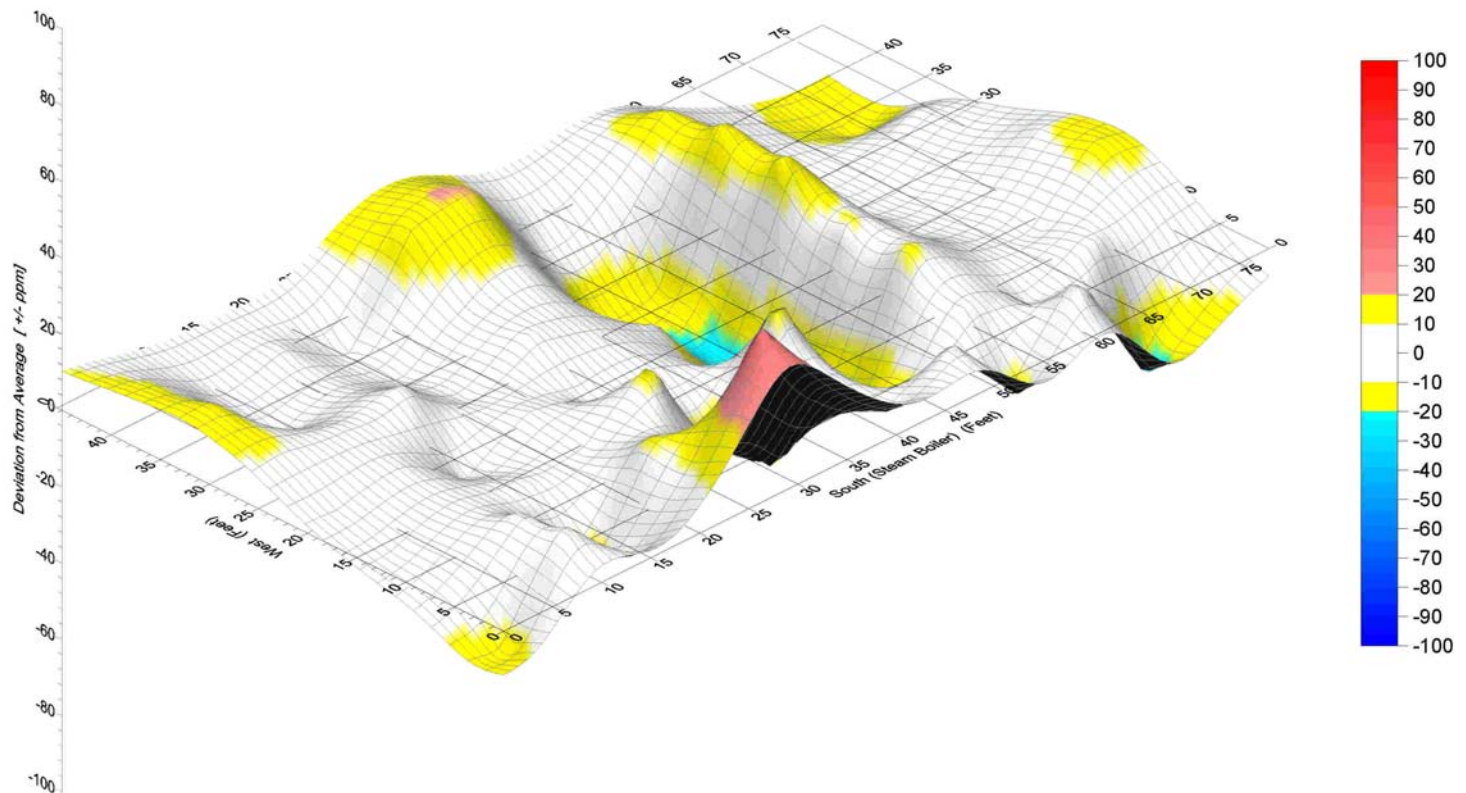

AIG Tuning:
 Template of
 what areas in
 the SCR reactor
 are influenced
 by which AIG
 tuning valve

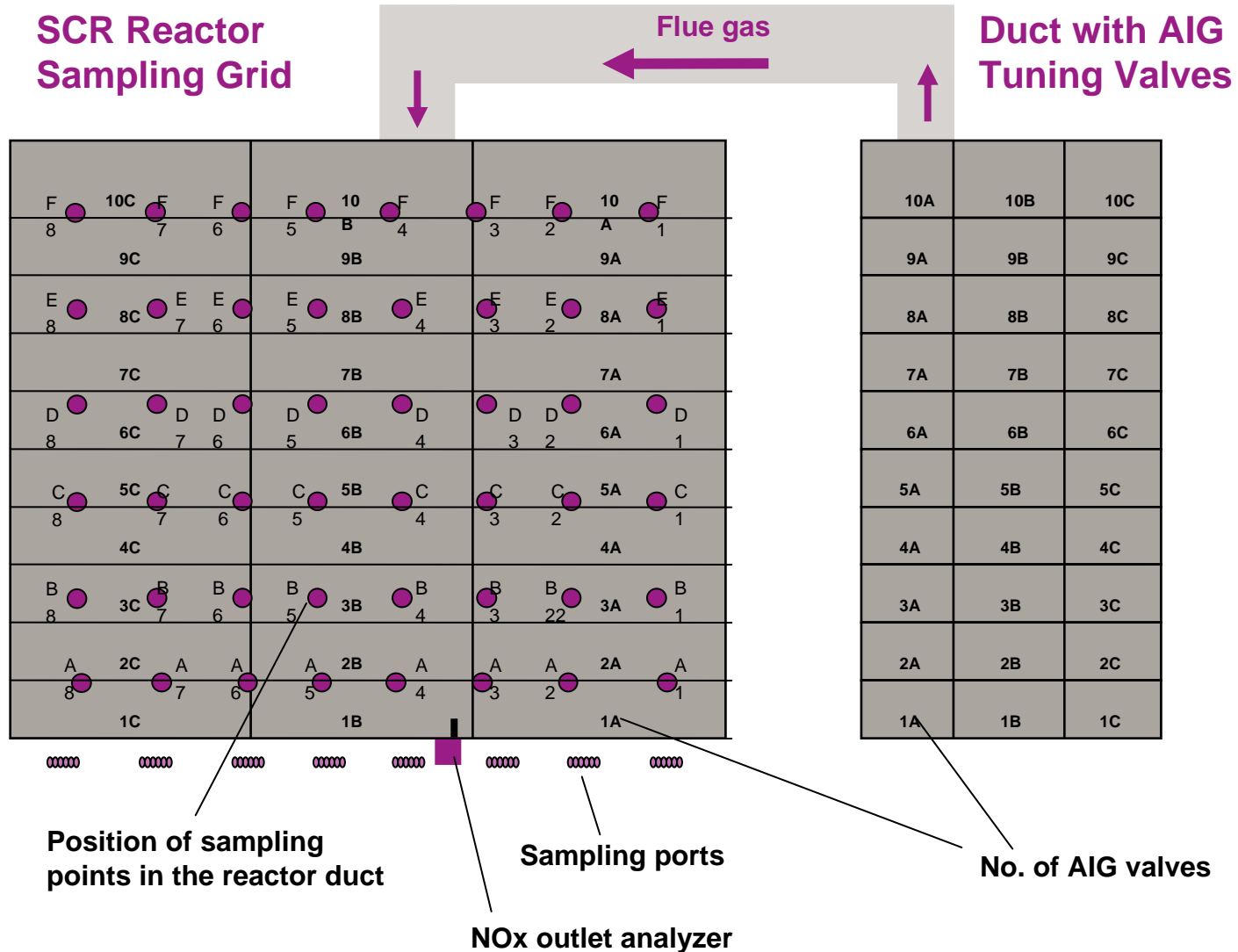

Evonik Energy Services



**AIG Tuning:
Measurement 1
Showing the
differences
from the
average for
each point
measured, each
value range
color coded**

1	2	3	4	5	6	7	8	AV	
41	37	42	44	41	38	41	43	41	
46	43	45	46	45	40	45	47	45	
52	50	50	49	50	45	48	50	49	
52	51	52	53	52	46	48	49	50	
53	49	51	52	52	45	49	49	50	
52	49	50	51	50	45	48	49	49	47
-6	-10	-5	-3	-6	-9	-6	-4		
-1	-4	-2	-1	-2	-7	-2	0		
5	3	3	2	3	-2	1	3		
5	4	5	6	5	-1	1	2		
6	2	4	5	5	-2	2	2		
5	2	3	4	3	-2	1	2		
2	-1	1	2	1	-4	-1	0		

Measurement 1

green	20	0 - 2
yellow	12	3 - 4
orange	13	5 - 6
red	1	7 - 8
violet	2	>9

Evonik Energy Services



**AIG Tuning:
Measurement 2
Showing the
differences
from the
average for
each point
measured,
each value
range color
coded**

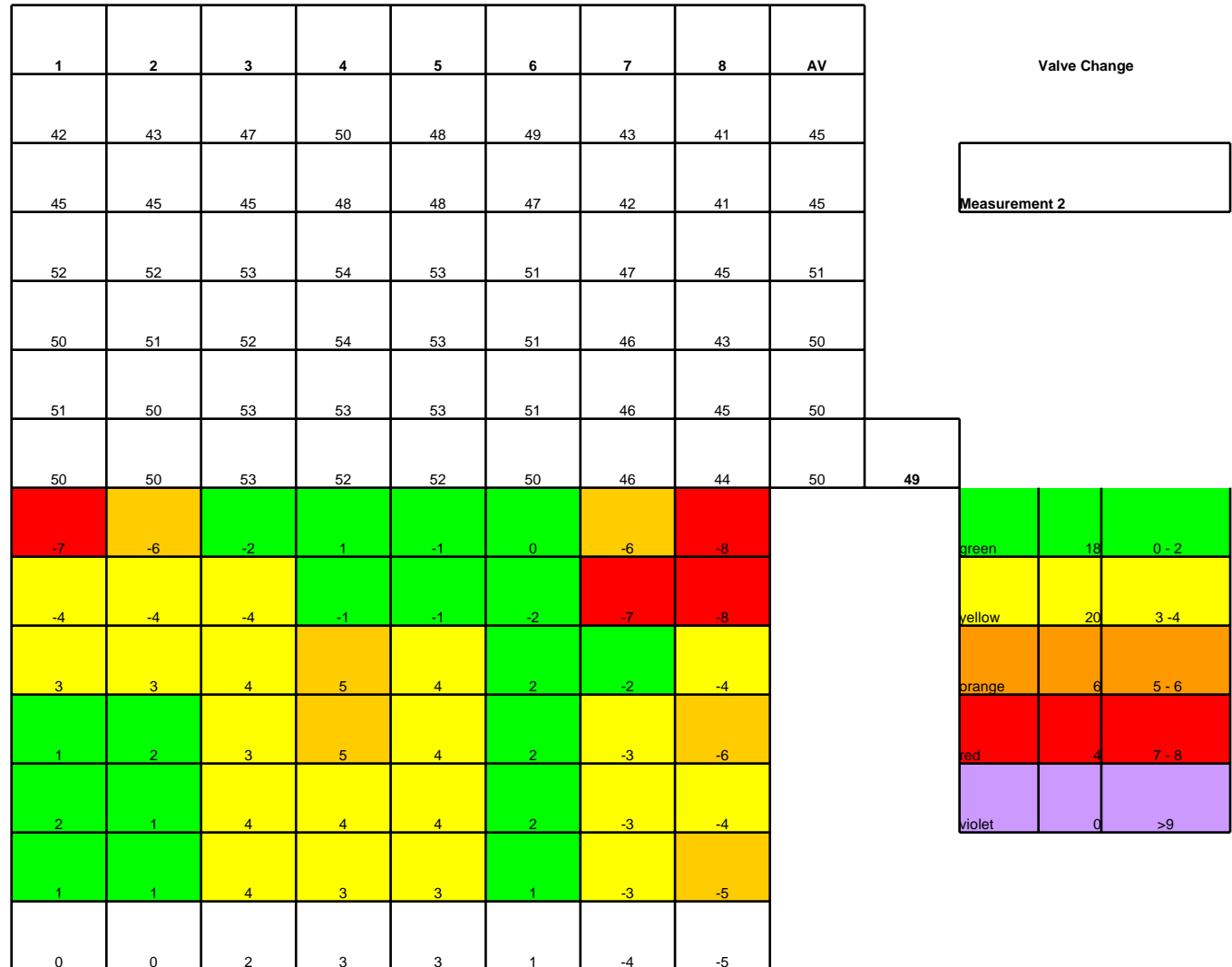

AIG Tuning: “As-Found” Data After O₂-Correction

		Nitric oxides concentration at point of grid [ppm] realed to 3 Vol.-% oxygen										Mean value	Mean value working plane
		South (Stack)											
		1	2	3	4	5	6	7	8				
East	A	59	59	105	87	91	102	122	119			93	95
	B	57	63	81	88	85	86	119	114			87	
	C	71	85	102	115	98	100	137	122			104	
													57
													Maximum value
													137
													Standard Deviation
													22
lean value		62	69	96	97	92	96	126	118				

AIG Tuning:
Side view
example of
where valves
are located
with respect
to the reactor

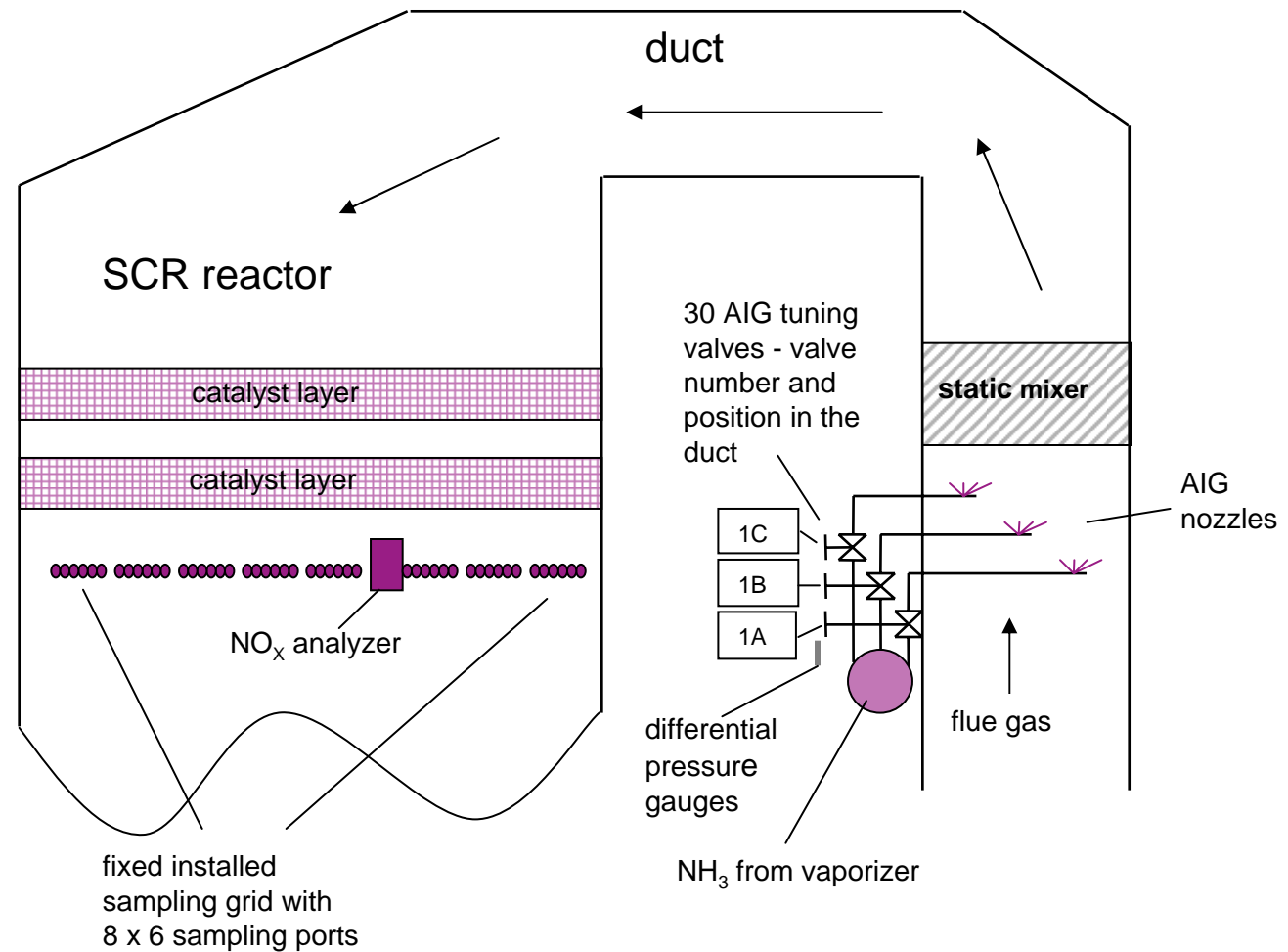



? Question ?



EVONIK
INDUSTRIES



EVONIK
INDUSTRIES